

TERMOSTATO MOD. TS-RM  
THERMOSTAT MOD. TS-RM

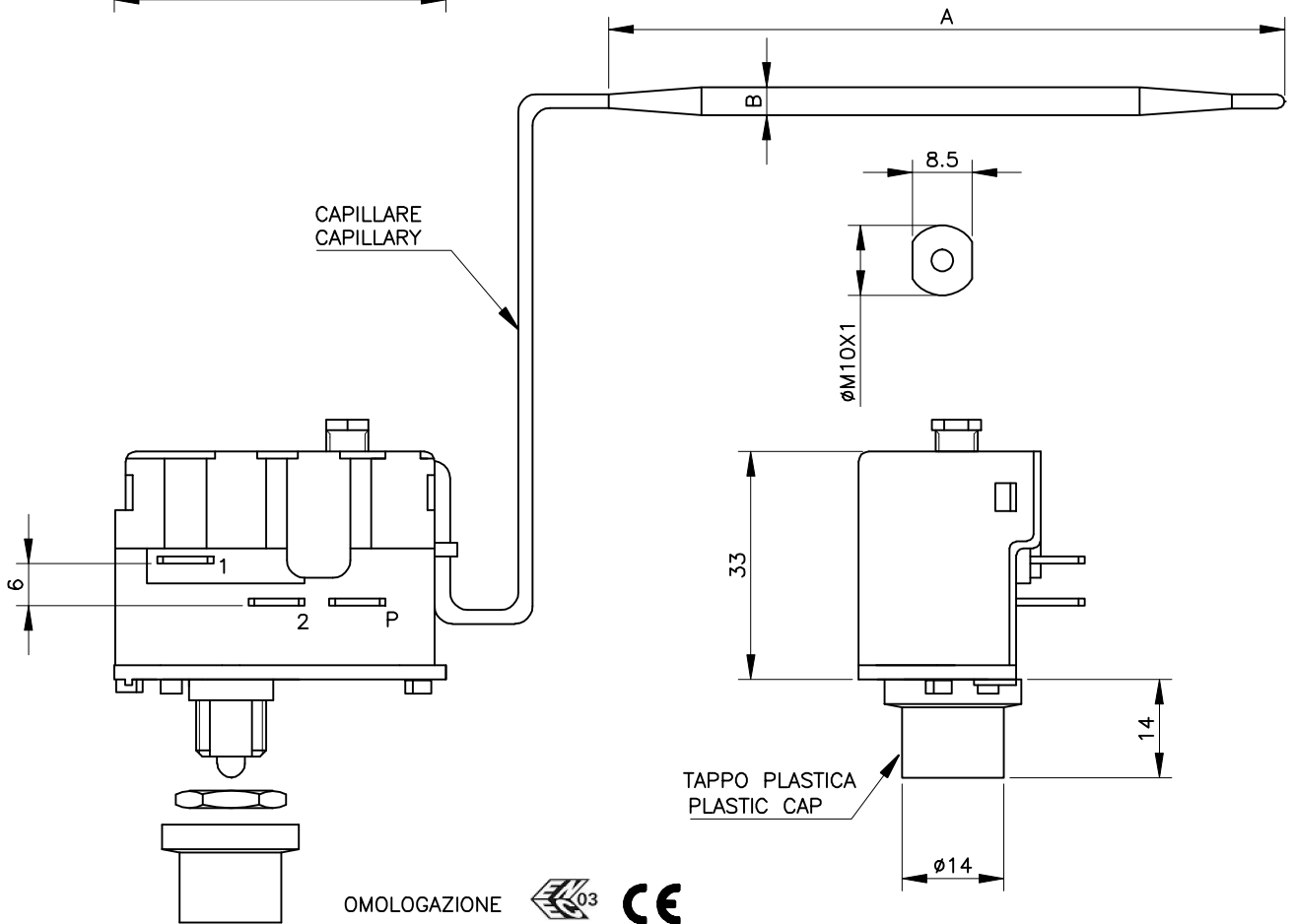

OMOLOGAZIONE

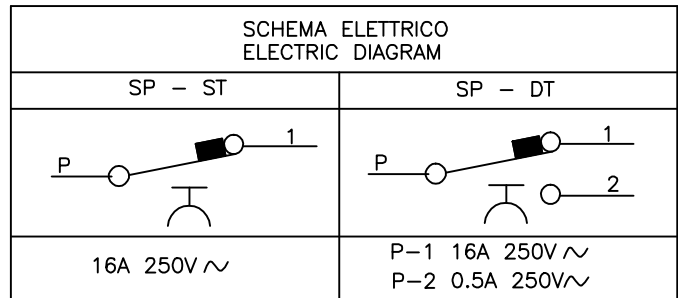
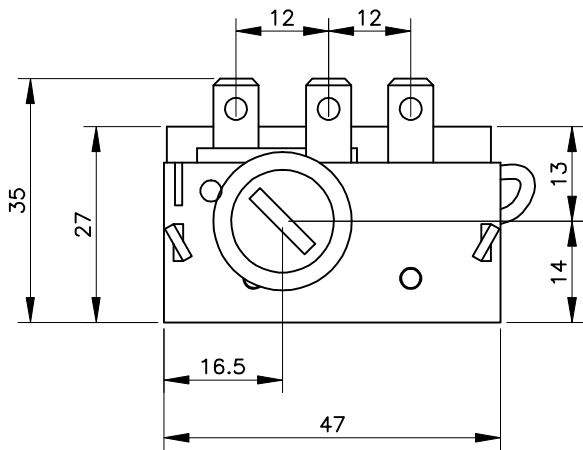
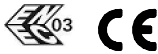

RAGGIO MINIMO DI PIEGA CAPILLARE : 5mm  
TARATURA IN BAGNO NORMALIZZATO

SCALE DI TEMPERATURE DISPONIBILI A RICHIESTA : DA +40°C A +400°C

TERMINALI FASTON 6.3mm

VERSIONI CON CAPILLARE E BULBO IN RAME O IN ACCIAIO INOX

ISOLAMENTO CLASSE II

APPROVALS

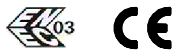

MIN CAPILLARY BENDING RADIUS 5 MM

CALIBRATION IN LIQUID BATH

TEMPERATURE RANGE ON REQUEST FROM +40°C TO +400°C

CONNECTION TABS 1/4"

VERSIONS WITH CAPILLARY AND BULB IN COPPER OR STAINLESS STEEL

INSULATION CLASS II